

LEUCOline

H I G H L I G H T S 2 0 2 6



Precision Pays Off. Profit Follows.

Innovative jointing cutters for top-level manufacturing

More on page 14

CONTENT



Our tools and services make production processes more efficient and improve the quality of the results. **Magentify Wood Processing.**

- 4 **Raw material prices are rising. Take advantage of opportunities**

SAW BLADES

- 8 **Panel cutting saw blades with a cutting width of just 4 mm. MAGENTIFY YOUR CUT**
- 9 Saw blade solution for solid-core materials
- 10 Saw blades for trimming without scoring
- 11 LEUCO g5-System expanded – perfect cutting quality on optimization crosscut saws

RUN-THROUGH

- 12 Hoggers UniTec A and UniTec D – optimally tailored to different workpiece materials
- 14 **Innovation that delivers results: Fibonacci jointing cutters at Stöcklin Küchen. MAGENTIFY YOUR EFFICIENCY**

CNC

- 16 LEUCO p-System shank-type cutters: Ideal for trimming on "Performance.cut"
- 17 LEUCO DIAREX: Robust, high-performance shank-type cutter for everyday CNC use
- 18 **End mills with air passage for improved cooling and chip evacuation. MAGENTIFY YOUR OPTIONS**
- 20 Synchronous swivel cutterhead—perfect for jointing and chamfering on 3-axis CNC machines

COMPOSITES

- 21 High-performance coatings: Maximize the productivity of composite machining tools

SOLID WOOD

- 22 **Optimally designed finger joint cutters: Longer edge life, better lamella quality. MAGENTIFY YOUR CAPACITY**
- 23 Micro finger joint cutters can be resharpened up to 10 times



8



9



10



11

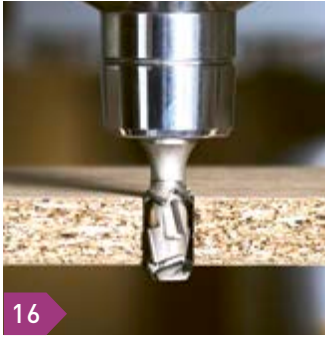

16



17



18



24



20



22



23



27



28

DATA

- 24 LEUCO Tool Info App enhanced: New features for structured tool data

COMPANY

- 26 LEUCO Thailand: 25 years
- 26 Sharpening service: Global expertise for maximum edge life
- 27 LEUCO France: New CEO
- 28 50 years of LEUCO production in Beinheim – Center of Excellence for circular saw blades

Editorial: LEUCO Ledermann GmbH & Co. KG,
Willi-Ledermann-Str. 1, D-72160 Horb am Neckar
T +49 (0) 7451/93-0
info@leuco.com
www.leuco.com
Editorial deadline: April 17, 2026

Raw material prices are rising. Take advantage of available opportunities.

THE RESULT IS WHAT MATTERS.

Raw materials, energy, logistics - costs along the entire value chain are rising noticeably. This development affects all market participants equally. Even we at LEUCO cannot avoid passing on higher raw material prices.

» "Conditions in general are challenging – but not without alternatives."

LEUCO Executive Committee members
(from left to right):
Roland Günther (COO),
Daniel Schrenk (management spokesperson, CEO),
Frank Seifert (CFO)



We are well aware that: High tool prices are not an abstract figure for our customers, but a concrete burden in their day-to-day business.

THINKING ABOUT THE RESULT IN RELATION TO PRICE

Not a new insight, but more important than ever in the current circumstances: The decisive factor is efficiency. What does a tool achieve over its entire service life? What overall package does a supplier offer?

WHAT DOES THAT MEAN FOR THE WOOD, FURNITURE AND COMPOSITES INDUSTRY SEGMENTS?

There are two main areas in which production has room for maneuver. The first and most obvious thing to do is to check how the performance and benefits of the purchased tool can be increased. The second is to identify and reduce the costs that arise during processing.

THERE IS NO ONE-SIZE-FITS-ALL SOLUTION - BUT RATHER MANY COST-EFFECTIVE ADJUSTMENTS

- | **Economy:** longer edge life, reduced energy consumption
- | **Quality:** high processing quality, less rework and fewer rejects, etc.
- | **Handling:** the simpler, the lower the set-up costs and machine downtime
- | **Versatility:** what the tool can be used for
- | **More efficient processes:** e.g. saving one pass, higher feed rates, use of digital tool information and organization

WHY ADVICE IS MORE IMPORTANT THAN EVER

At LEUCO, consulting is always a central component in the exchange with customers. Today it is more important than ever.

Not because the principle has changed - but because the leverage has increased. The higher the prices along the value chain, the greater the effect of optimization.

With their technical expertise and experience,

LEUCO tool consultants quickly assess the above-mentioned parameters for individual companies and then calculate and compare the cost-effectiveness of possible measures.

CONCLUSION: NOW IS THE RIGHT TIME

Conditions in general are challenging - but not without alternatives. Companies that act now will secure clear advantages:

- | Greater efficiency
- | More stable processes
- | Better cost control

The decisive factor is not the individual measure, but rather the holistic approach. and it starts with a conversation.

Talk to the LEUCO tool experts now – worldwide.

CONCRETE STARTING POINTS TO PUT INTO PRACTICE

APPROACH NO. 1

TARGETED EXTENSION OF EDGE LIFE,
reduction of set-up times and
machine downtime

» Select optimized geometries and material-specific designs instead of standard solutions

The LEUCO range includes around 8,000 tools, a wide variety of tooth configurations, shear angles, cutting geometries, and more, precisely tailored to many materials, panel thicknesses, machine types, etc.



Example: Saw blade for PMMA materials



Jointing cutters for a variety of applications

» Establish tool checks and maintenance

Tools should not be used beyond their optimum edge life. "Over-used" tools have severely rounded cutting edges and require increased material removal during sharpening. This means fewer possible sharpening cycles and in turn a needlessly shortened overall service life of the tool.

» Clean tools cut better - and longer

Regular cleaning prevents build-up on the edges and unnecessary wear. Tips & Tricks for reshaping areas, sharpening service cycles and cleaning can be found at:

→ <https://www.leuco.com/DE/DE/services/schaerfervice>



» Optimize clamping technology

Example: Shank-type cutters: Compared to collet chucks (radial runout 0.02-0.06 mm), precise clamping elements exhibit significantly less radial runout - hydraulic expansion clamping systems <0.006 mm, heat-shrinking or power shrink chucks (Tribos) <0.003 mm. Users achieve a cleaner cutting pattern while unnecessary tool wear due to imbalance is reduced.

» Important: Maintaining optimum clamping depth

The optimum clamping depth is not identical to the legally prescribed minimum clamping length, but makes optimum use of the clamping forces of the clamping element. The benefits are minimal radial runout, no premature wear and greater process reliability.



Ideal clamping depth

» Fine tune application parameters

Feed rate, RPM and application are directly related and should be considered as a unit. The smallest deviations have a direct impact on edge life and process costs. In CNC processes, for example, too low a feed rate usually leads to excessive tool heating, which can in turn cause chipped cutting edges.

» Ensure ideal chip guidance to the extraction system

Double cutting is reduced and thus unnecessary tool wear.

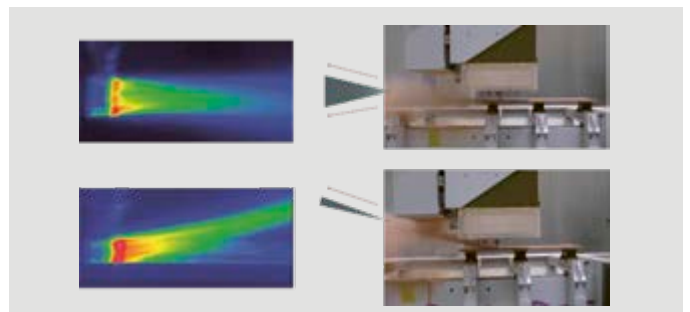

Bottom: Chip jet is ideally directed towards the extraction system



t3-System copes well with large chip volumes

Continued on the next page...

APPROACH NO. 2

INCREASE UTILIZATION TIMES WITH CLEVER TOOL CONCEPTS



» **Combination tools can offer economic advantages, e.g:**

in the form of a clamping element extension in conjunction with a standard cutter instead of a long cutter. Other examples include the 3-in-1 cutter for solid core materials and the DIAREX combination right/left cutter. Particularly interesting for changing applications.

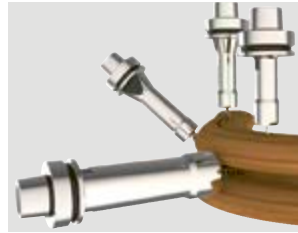

APPROACH NO. 3

USING DIAMOND-TIPPED TOOLS CONSCIOUSLY

» **The use of diamond-tipped tools instead of carbide-tipped tools can be an alternative.**

Whether the switch is technically possible depends on the application. This consideration is particularly interesting for circular saw blades, cutters with replaceable cutting edges and edge finishing cutters. Polycrystalline diamond (DP) is 10 - 100 times more abrasion-resistant, depending on the application, and the edge life is correspondingly longer.

LEUCO DIACURVE cutters with a single edge life (disposable cutters) can also be an alternative to cutters with turnover knives or disposable HSS or VHW cutters if they are technically suitable. An application-specific cost-benefit calculation will provide clarity.



LEUCO DIACURVE cutter

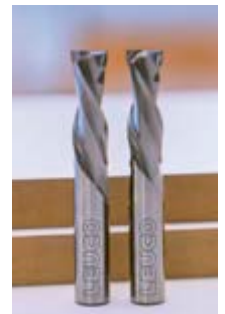

VHW cutter

APPROACH NO. 4

EXTEND EDGE LIFE SIGNIFICANTLY WITH NEW TOPCOAT COATINGS

» **topcoat coatings for VHW cutters, turnover knives, planing and finger joint tools significantly increase the hardness of the cutting edge.** Depending on the coating and application, a 3 to 10 times longer edge life is possible. Recoating is not necessary after resharping.

The 3 to 10-times longer edge life is achieved again, even after resharping.

Conclusion: The higher the cost of uncoated tools, the more attractive coated versions become.

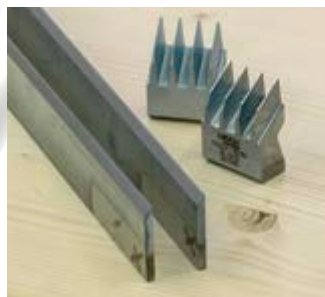

APPROACH NO. 5

MAKE TARGETED USE OF INNOVATIONS,
BREAKING NEW GROUND

» Innovation is not an end in itself for LEUCO. In actual practice, they definitely offer new, previously unimagined possibilities. Examples:

p-System cutters with a 70° shear angle for example, allow the cutter to be moved out over the edge without the need for re-insertion when cutting against the feed.

Fibonacci arrangement of cutting edges: This arrange ensures that there is no overlapping area. No more height adjustment with varying panel thicknesses - with the Fibonacci jointing cutter from LEUCO.



APPROACH NO. 6

SIMPLIFY ORGANIZATION AND
INFORMATION FLOW



» Digital solutions create transparency and reduce non-productive time in everyday life.

The free "LEUCO Tool Info" app provides all relevant information on LEUCO tools in one place. The app can be downloaded at any time from the Google Play store and Apple app store.

We have been a system partner of "twinio" from the very beginning in the area of tool organization with the possibility of connection to a machine.

APPROACH NO. 7

MAKE PURCHASING EFFICIENT

» In Germany, end customers can order 24/7 in the LEUCO online store with a 2% online discount:

<https://shop.leuco.com>



PROVIDING IMPETUS, INCREASING SCOPE FOR ACTION

Background: In mid-April 2026, LEUCO introduced an inflation surcharge to compensate for extreme increases in raw material costs. Tungsten, for example, is a component of tungsten carbide tips. The filler metal for brazing the teeth contains silver.

This makes it all the more important for us to give you solution-oriented ideas with this article. Our tool experts are at your disposal - as partners, worldwide - if you would like details.

Editorial deadline for this article: April 17,2026

More inspiration
on the following
pages! »»»»



PANEL SIZING SAW BLADES

4-MILLIMETER PRECISION: SLIM CUT, GREAT EFFECT

LEUCO turns a market impulse into a new tool solution. For panel sizing saws, the company has developed a circular saw blade with a cutting width of just 4.0 mm, significantly thinner than the previously standard 4.4 mm and 4.8 mm - with the same quality. The Horb-based manufacturer is thus helping a trend to break through: Narrower designs are increasingly in demand because they improve resource efficiency, process stability and cost-effectiveness in equal measure.

What sounds like a few tenths of a millimeter changes the entire machining process. The reduced cutting width minimizes cutting forces, chip volume and waste. At the same time, energy consumption and motor load are reduced. Depending on the model of the panel sizing saw, the load on the dust extraction system is also reduced.

SLIM DESIGN, RELIABLE PERFORMANCE

The development of the 4.0 mm version places high demands on stability and precision. Despite the smaller dimensions, smooth running, edge life and cutting quality must remain at the usual high level. This shows the strength of the LEUCO solution: The new version combines a slim design with reliable performance, even with laminated and demanding panel materials.

The lower cutting forces and reduced chip volume reduce the mechanical load on the machine and increase the efficiency of the system. This increases cost-effectiveness - especially for larger quantities.



Matching carbide or diamond-tipped scoring saw blades complement the thinner main saw blades. Users of the thinner blades thus have the same applications at their disposal, supplemented by the advantages of the 4.0 mm blades.

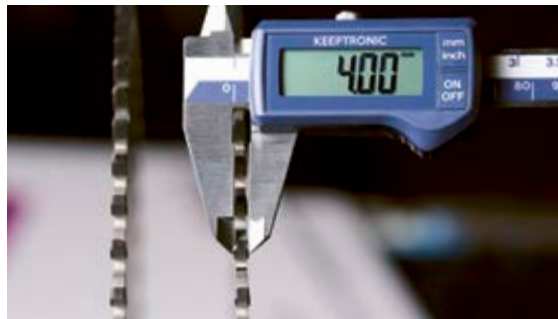

LEUCO saw blade in direct comparison: The new 4.0 mm version compared to the previous 4.4 mm version (left) makes the technical development visible - with a significantly reduced cutting width and unchanged performance and stability.

RELIABLE PERFORMANCE, FAST DELIVERY

The 4.0 mm versions are available for the high-quality carbide-tipped saw blades in the LEUCO Q-Cut family: Q-Cut G6, Q-Cut G6 nn-System, Q-Cut TR-F-K and Q-Cut G5. The main blades are available from stock and can be delivered immediately - including three scoring circular saw blades in a carbide-tipped design (tooth geometry: KO-WS, KO-F, KO-HR) and now with DP tipping (tooth geometry: KO-HR).

With the 60 mm mounting hole, the blades are primarily suitable for all Homag panel sizing saw models. For the newer models with new extraction solutions, Homag promises improved chip evacuation in combination with the thinner cutting widths. The reduction in cutting pressure varies depending on the tooth geometry.

PRECISE ADJUSTMENT, SIGNIFICANT BENEFIT

The minimized cutting width is the result of close cooperation between machine manufacturers and LEUCO. Development impulses from the market are consistently noted and transformed into solutions ready for series production.

With the 4.0 mm model, LEUCO is underlining its role as a technology partner to the industry and demonstrating how precise adjustment can result in a tangible productivity advantage in practice.

YOUR CUT

MAGENTIFY

SAW BLADE SOLUTION

SOLID SURFACE: DEVELOPED FOR THE TOUGHEST PLASTICS

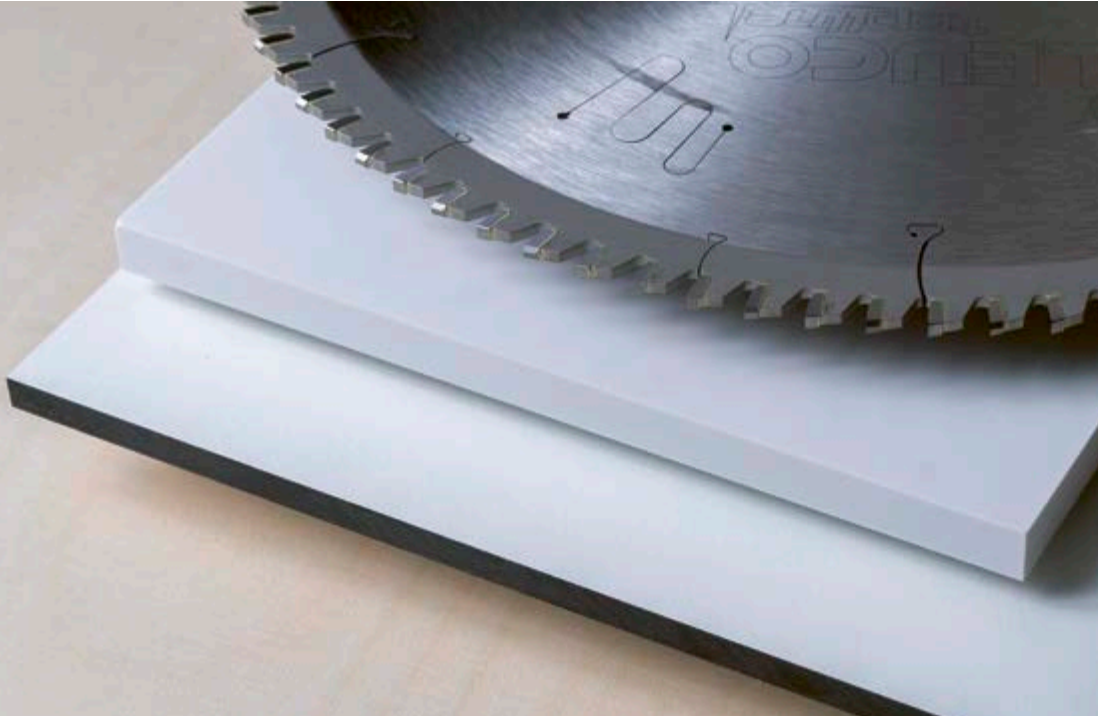

Clean cutting edges in highly compacted, mineral materials: The LEUCO "Solid Surface" circular saw blade is specially designed for particularly hard and wear-intensive plastics.

Among its four high-performance circular saw blades for plastics, LEUCO offers a new design that effortlessly masters even extremely dense panel materials: the "Solid Surface TR-F-FA" circular saw blade.

Plastics in interior design and furniture construction are offering ever greater performance - and becoming more demanding to work with. In addition to classic thermoplastics, thermosets and mineral-reinforced materials are increasingly being used. Their hardness and abrasiveness put circular saw blades to the test.

PRECISION DESPITE HIGH MATERIAL STRESS

The solution: The new LEUCO "Solid Surface TR-F-FA" circular saw blade is specially designed for particularly hard, homogeneous and wear-intensive panel materials. These include high-pressure laminates (HPL) and also thermoset materials used for branded products such as CORIAN®, AVONITE®, VARICOR® or HI-MACS®.

The tooth geometry and tungsten carbide grade are matched to demanding materials and ensure clean cutting edges and long edge lives - even in economical series applications. The Solid Surface circular saw blade is available with a diameter of 303 mm. It is suitable for all standard panel thicknesses and can be used on circular table saws from all manufacturers as well as on vertical panel sizing saws. In stock and now available...

THE RIGHT SOLUTION FOR EVERY TYPE OF PLASTIC

In principle, the processing of plastics is as varied as their composition. While thermoplastics such as polycarbonate or polystyrene tend to heat up and melt during sawing, thermoset materials are brittle and abrasive. The decisive factor is a tool design that is suitable for the material.

LEUCO therefore offers a coordinated range of four specialized circular saw blades. The "Solid Surface TR-F-FA" circular saw blade is designed for processing hard mineral-filled and wood-based materials:

- | The HW "TR-F K Anti-Fingerprint" sizing saw blade with a diameter of 300 mm for precise, material-friendly cutting without scoring and flaring on the surfaces of anti-fingerprint materials and conventional plastics.
- | The HW "Plastics TR-F-FA" sizing saw blade with a diameter of 303 mm for transparent PMMA panels such as Plexiglas® as well as for light-proof polystyrene panels.
- | And the HW "Plastics WS-FA" sizing saw blade with a diameter of 303 mm for finish cuts in thicker thermoplastic panels, including PMMA over 15 millimeters and polystyrene over 20 millimeters in thickness.

With this specialization, LEUCO supports wood and plastics processing companies in processing even demanding materials safely, economically and with high cutting quality.



In addition to table saws and chop saws, the nn-System DP Flex can also be used on CNC machines.

EXCELLENT CUTTING QUALITY

CUTTING (MOSTLY) WITHOUT SCORING

With the carbide-tipped g5-System and the diamond-tipped nn-System DP Flex, LEUCO offers two high-performance saw blade alternatives for professional woodworking. Both product families stand for precise cuts, clean edges and practical use in a wide range of applications. In practice, users usually use the saw blades without a scorer because the cutting quality on the underside is usually already very good.

CARBIDE-TIPPED G5-SYSTEM

The g5-System stands for excellent cutting quality for a wide range of materials. The distinctive G5 tooth group geometry ensures tearout-free edges - even with laminated wood-based materials, solid wood or plastics. Users report that, particularly for standard format, clipping and miter cuts, the quality on the underside is so convincing that a scorer is often superfluous in practice. The g5-System also scores points with its reduced noise level and long edge life thanks to the high-quality tungsten carbide grade HL Board O4 plus.

DIAMOND-TIPPED NN-SYSTEM DP FLEX

With the nn-System DP Flex, LEUCO offers a diamond-tipped solution for even more versatile applications. Laminated chipboard and MDF panels, fibrous solid wood, plastic or aluminum composite and even cement-bonded board - the range of applications is exceptionally broad. The DP-tipped cutting edges ensure extremely long edge lives. The small chip spaces mean a significantly lower noise level and the hollow-back tooth configuration provides a very fine cutting quality. Results in real-life practice: The cuts on the underside are so convincing that users generally use the saw blade without a scorer.

LESS SET-UP TIME IN EVERYDAY LIFE

"The fact that our customers generally use the saw blades without scorers is confirmed by the feedback and our scorer sales figures in this area," explains Markus Erkenbrecher,



Markus Erkenbrecher, Product Manager for saw blades at LEUCO

er, Product Manager for saw blades at LEUCO. "Only around three percent of users of the nn-System DP Flex have also opted for a scorer. Normally, you want high sales figures. As a former carpenter, I know how tedious and time-consuming the adjustment can be - that's why I'm particularly pleased with the good cutting results without a scorer."

With the g5-System (only 3.0 mm cutting width) and the nn-System DP Flex (2.5 mm cutting width and up to 20 times the edge life compared to standard carbide-tipped blades), LEUCO users have two proven saw blade alternatives for high cutting quality, virtually without scoring.



g5-System in use: Cross-cut oak without tearout on the underside

LEUCO CIRCULAR SAW BLADE WITH A SYSTEM

FAST. CLEAN. G5.

Designed for optimizing chop saw machines: The new G5 saw blade from LEUCO delivers chip-free edges and up to 30 % longer edge life for chop cuts in solid wood, MDF and HDF strips.

Manual and fully automated under-table cross-cut, sliding table and through-feed saws are designed for maximum performance: high feed rates, short cycle times, changing programs. In this environment, it is not just the machine that determines efficiency and throughput; the tool is the decisive factor. This is where the g5-System circular saw blade from LEUCO comes in.

LOWER PRESSURE, IMPROVED CUTTING QUALITY

The heart of the blade is a group of five teeth: a flat tooth as the guide tooth, followed by four alternating teeth. The G5 geometry distributes the forces evenly, thus reducing the cutting pressure and allowing the blade to glide more easily and quietly through the material.

Specifically designed for optimizing chop saws, the geometry combines a moderate positive hook angle of +2° with shear angles between 5° and 10°, depending on the cutting width. The g5-System circular saw blade is designed

for the precise cutting of solid wood, wood-based materials as well as laminated materials and composite materials such as slats, strips, board material, MDF or particle board. The hard-wearing tungsten carbide grade HL Board O6 is used as the cutting material - perfect for the impact loads during chop cuts.

The result can be seen directly on the workpiece: smooth surfaces, clean edges, a scratch-free cutting pattern, even at high cycle rates. At the same time, the cutting pressure is reduced, which means that the machine consumes less energy.

LONGER EDGE LIVES, QUIET OPERATION

In practice, the tool achieves up to 30 % longer edge life compared to conventional HW circular saw blades. Fewer tool changes increase productivity per shift.

The 30 mm mounting hole is H7-honed and ensures precise centering and low-vibration, quiet operation - even at high speeds. It can be used on standard machines. Blades for optimizing chop saws are available in the diameter range from 400 to 630 mm.

To summarize: The G5 geometry is used for optimizing chop saws to achieve clean

edges, lower cutting resistance and fewer tool changes.

The LEUCO experts can advise you on the optimum application and create individual sharpening service concepts for consistent and efficient machine operation.

Now available: LEUCO g5-System saw blade for optimizing chop saws - for long edge life and maximum quality with chip-free and scratch-free cutting surfaces in wood-based materials, solid wood

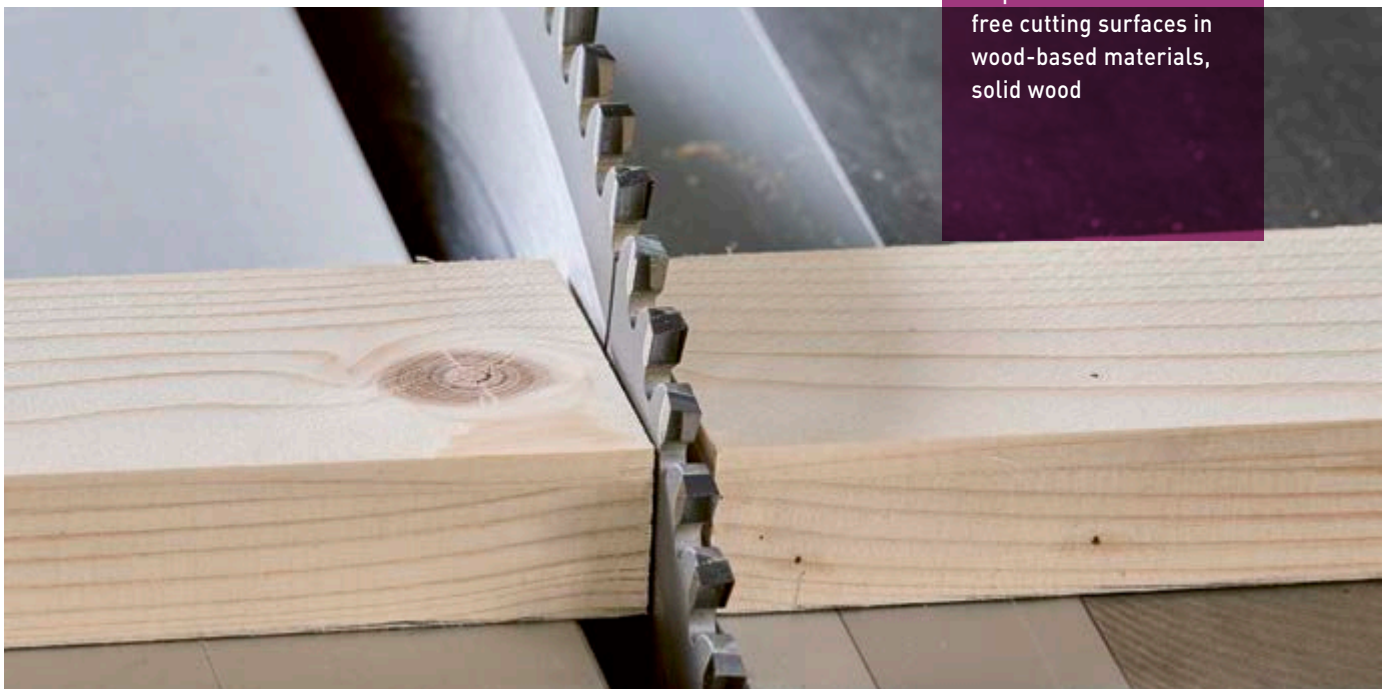

POWERFUL TOOL TECHNOLOGY

LEUCO HOGGERS: TWO SPECIALISTS, ZERO COMPROMISES

Twice as strong: With UniTec A and UniTec D, LEUCO offers specialized hoggers for the industrial processing of wood-based materials and laminated panels. UniTec A is particularly suitable for harder surfaces and a variety of applications. UniTec D shows its strengths on sensitive, fibrous surfaces such as veneer, paper or foil. Both tools have a constant cutting width of eight millimeters and an above-average resharpening area of five millimeters. This enables clean hogging with the highest cutting quality in the top and core layers. At the same time, the solutions offer long edge life and economical processes.

In practice, one hogger for all workpiece materials is often a compromise. LEUCO therefore relies on two specialized tools. "Every material places different demands on the tool cutting edge and the cutting pressure," explains Product Manager Robin Henssler. "With UniTec A and UniTec D, we offer two hoggers that specifically take these differences into account. At the same time, they process an enormous range of materials to the highest quality standards."

2 VARIANTS INSTEAD OF A STANDARD TOOL

As a universal hogger, UniTec A is suitable for practically all surface materials. The ascending cutting edge optimizes the cutting pressure and thus enables versatile use with long edge life. Also ideal for abrasive workpiece materials or high hogging volumes.

The specialist for sensitive surfaces containing fibers: UniTec D. The cutting edge is descending, which means that the finish-cut edge leads and performs a scoring function. In this way, fibers and materials are cleanly separated and perfect cutting edges for veneer, paper or foil coatings are achieved.

Both hoggers can be used for panel thicknesses from eight millimeters and are suitable for a wide range of wood-based materials. Special focus is placed on the highest quality requirements in the core layer, even for particle board or wood-based materials with recycled content.



"The UniTec A and UniTec D hogger variants are each designed for a specific range of materials."

Robin Henssler,
Product Manager for
through-feed at LEUCO

VERY LONG EDGE LIFE THANKS TO OPTIMIZED GEOMETRY

The above-average resharpening area of five millimeters allows additional sharpening cycles and extends the tool life by up to 25 % compared to other products on the market.

Special geometries on the cutting edges reduce wear and reduce the impact sensitivity of the DP cutting edges. This increases the edge life, especially with abrasive workpiece materials and carrier materials with a higher recycled content.

RELIABLE CUTS AND STABLE PROCESSES

Pre-cutting and main cutting edges ensure precise cutting edges in both variants. The constant cutting width of eight millimeters ensures identical stock removal widths during all sharpening cycles. Workpiece quality and processing parameters are maintained throughout the entire life cycle of the blade.

The integrated Chip-Meister technology optimizes chip evacuation and prevents multiple hogging, which protects the tool cutting edge. Processes remain reliable, even at high feed rates or high stock removal rates in through-feed machines.

IDEAL MACHINE ENVIRONMENT

The prerequisite for using the UniTec hoggers is a through-feed system with a double hogging unit. The LEUCO standard range

covers a spectrum from Z24 to Z60 and recommends feed rates from 30 to 75 m/min. The UniTec hogsers are compatible with all standard machine holders Ø35 and Ø40 and have an interface for the s-System Ø160. Individual requirements can be covered by special solutions. UniTec A and D are also suitable for scoring (scribing).

CONCLUSION: HIGH EFFICIENCY, PRECISION AND COST-EFFECTIVENESS

UniTec geometries, special cutting edge geometries and Chip-Meister technology guarantee maximum cutting quality with minimum wear. The generous resharping area allows several sharpening cycles to be carried out, which significantly increases tool life.

Users benefit from stable cutting edges, reproducible stock removal rates and efficient production - a clear advantage for precise and economical panel processing.

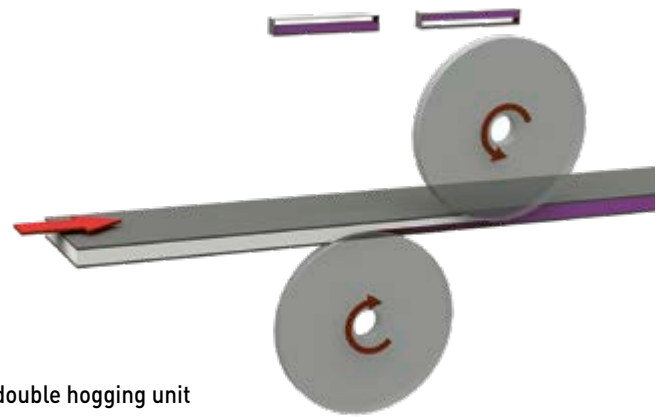

Principle for double hogging unit

Detailed view of the LEUCO tooth geometry for cutting tools, with additional top view of the insert to illustrate the resulting cutting pattern.

UniTec A



UniTec A with ascending cutting edge, designed for universal material mix and harder surface materials.

UniTec D



UniTec D with descending cutting edge and leading edge, optimized for fibrous surface materials.



Founded in 1943, the Swiss kitchen manufacturer from Aesch near Basel is now in its third generation, representing high-quality furniture production combined with maximum flexibility: Kitchens can be manufactured within a week if needed. "And if a customer wants a custom shade in addition to our 100-plus standard colors, we make it happen," explains Sandor Götz, production manager at Stöcklin Möbel AG. He sums up the company's commitment as follows: "I'd say: perfectionism. Because our quality standards are truly high."

YOUR EFFICIENCY

MAGENTIFY

PERFECTION IS NO ACCIDENT

JOINTING CUTTERS AND SCRAPER

How is top-tier Swiss manufacturing achieved? Through close collaboration between production and tool development. Stöcklin Möbel AG regularly serves as a pilot customer for LEUCO, putting new solutions directly into the application. This is how innovations are created where they matter most: at the machine, in the process, in the result.

FIBONACCI CUTTERS: LEUCO TECHNOLOGY AS A GUARANTEE OF QUALITY

Central to Stöcklin's above-average manufacturing standards is the DIAREX airFace Fibonacci jointing cutter from LEUCO. Discovered at LIGNA in 2023 by then-plant manager Hubert Kern, the kitchen manufacturer was one of the first to use the new tool with its innovative tooth geometry. "The cutters weren't in the catalog or on the market when we saw them," says Sandor Götz.

The Fibonacci jointing cutters are suitable for both laminated particle board with PUR edging and for applications with the highest quality demands, such as laser edging. The Fibonacci cutter particularly demonstrated its strengths with anti-fingerprint panels featuring a laminate structure. "These materials," says Sandor Götz, "have increased significantly in recent years and are difficult to process." The cause lies in the finest surface imperfections: "The surface of the milled cutting edge looks like a jagged glass cutting edge if the tool isn't sharp and cuts with razor-sharp precision." This is a shortcoming, especially with dark decors: "It creates white lines on the panel."

The impact can be quantified: "For standard laminated panels, we achieved a 100 percent success rate; then the anti-fingerprint surface came along, and our success rate dropped to 50 to 60 percent." The new tool fundamentally changed that: "When we started using the Fibonacci cutter, we returned to our high quality standards."

The solution also offers economic efficiency: "It has become clear that we can achieve much longer tool life with this cutter—much longer," reports Sandor Götz. At the same time, regrinding costs have been significantly reduced: "Thanks to the longer edge life, regrinding costs are about 30 percent lower compared to the tools used previously."

Another advantage is tool reconditioning: "Through regeneration—that is, removing cutting edges that are no longer resharpenable and soldering new cutting edges onto the same body—the tool life is significantly extended and our costs are substantially reduced. 'With diamond-tipped jointing cutters,' emphasizes Sandor Götz, 'this is a key issue, as they are among the most expensive tools in operation.'

SCRAPER KNIFE: CLEAN EDGES WITHOUT MATERIAL FRACTURING

Another example of practice-driven development is the scraper knife with a chamfer to prevent material fracturing. The issue at hand is material fracturing—visual residues that occur during processing and are particularly visible on dark edges. "If you run your finger over it twice," explains Sandor Götz, "the material fracturing is gone. But in automated production, that's a problem."

A solution already existed for radius edges, but not for flat edges. "I took the problem to LEUCO and said: We need a solution for this," recalls Sandor Götz. The result: a specially developed scraper that specifically handles these critical areas. The effect is immediately visible in

Precision for the highest quality standards: The DIAREX airFace Fibonacci jointing cutter enables Stöcklin Möbel AG to achieve precise cutting edges even on demanding anti-fingerprint surfaces, thereby contributing to the high standard of production.



the process: The visual defects disappear without additional manual rework. Sandor Götz: "Now it's been solved cleanly and with high economic efficiency."

PARTNERSHIP AND SERVICE: RELIABILITY ENSURES SUCCESS

Around 95 percent of the tools used at Stöcklin come from LEUCO, which takes the collaboration beyond a traditional supplier relationship. "If LEUCO comes up with an idea, we might be testing it the day after tomorrow," says Sandor Götz, describing the short communication channels. Flat hierarchies and a high technological standard enable rapid testing of new developments in-house.

At the same time, Switzerland is considered a particularly sensitive market. "The quality standards," emphasizes Sandor Götz, "are extremely high. If a solution works here, it works everywhere." This makes the location particularly valuable as a benchmark of quality for development partners. For Stöcklin, the close part-

nership means one thing above all: fast and reliable support in day-to-day operations. "If I have an problem, someone from LEUCO is in the car and here the same day," says Sandor Götz. "The service is exemplary."

Sales Manager Erik Petersen of LEUCO Switzerland highlights the total package: "The combination of quality, service, and innovative strength creates real competitive advantages. Trust is the best foundation for this." Sandor Götz: "I am convinced that this successful partnership will continue for a long time to come."

Technical exchange in production: Sandor Götz (right) and Damien Rambach (left) from Stöcklin Möbel AG, Erik Petersen from LEUCO Switzerland, participant in conversation about new solutions.



Clean edges without rework: The scraper with a chamfer to prevent material fracturing from LEUCO ensures a uniform finish at Stöcklin Möbel AG and removes visual residues directly during the process.



Precise cuts and very long edge life at feed rates of up to 40 m/min thanks to p-System geometry in the top layers.

LEUCO p-SYSTEM SHANK-TYPE TRIMMING CUTTER: CLEAN EDGES AT MAX. FEED RATE

IDEAL FOR TRIMMING ON THE "PERFORMANCE.CUT"

The particular strength of the new tool highlight from Horb lies in the intelligent division of work along the edge. This is because the new LEUCO p-System shank-type trimming cutter combines two cutting geometries and thus unites the highest quality in the top layer with optimized chip flow in the core layer. The result: Excellent cutting pattern, even at extremely high feed rates of up to 40 m/min and extremely long edge life.

WELL THOUGHT OUT IN TWO WAYS

In the top layer, it works with a Z4 LEUCO p-System geometry. With a shear angle of 70 degrees, the p-System enables particularly precise, chip-free processing of the top layer - even with delicate decors. The benefits: Less waste and the edge can often be finished directly without an additional joining process. In other cases, minimal removal during edge trimming is sufficient.

In the core layer, the focus is on efficient processing rather than optical quality. LEUCO deliberately dispenses with the p-System geometry here and opts for a low shear angle. As the optical quality is less important in this area and the material is generally less abrasive and dense, a more robust cutting edge shape is used. The use of only two teeth in the core layer creates additional space, which is used for optimum chip evacuation and thus increases edge life. The result: less multiple hogging, consistently clean cuts and long-lasting performance.

FAST AND EFFICIENT

On the IMA Performance Cut, which is designed for high-performance cutting, the LEUCO p-System trimming cutter impressively demonstrates what productivity looks like today. Even at extremely high feed speeds of up to 40 m/min, the tool delivers an exceptionally clean and high-quality edge with its Z4 arrangement. For users, this means maximum speed without loss of precision.

LONG-LASTING AND EFFICIENT

The low cutting pressure of the patented p-System geometry protects the diamond-tipped cutting edges from rapid wear despite full cuts at high feed rates. Although still new on the market, the new LEUCO trimming cutter type exceeds the edge life of all cutters previously found on the market. As this also reduces set-up times, the cutter wins virtually every profitability calculation in this environment.

VERSATILE IN APPLICATION

The p-System trimming cutter is particularly suitable for processing all laminated wood-based materials, such as those encountered in furniture manufacturing, interior design or production of store fittings.

Important: This is not a nesting cutter. The tool achieves its full performance when the processing area is open at the bottom, as is the case on the "Performance.cut". However, the cutter can also be used for sizing / format processing on CNC console machines with the aforementioned benefits.

With the new p-System trimming cutter, LEUCO shows how quality and productivity can be increased through targeted further development of the tooth geometry. The cutter is available from stock in two dimensions for 16 and 19 mm thick panels.

LEUCO p-System trimming cutters are the new, economical cutter alternative for "IMA Performance.cut" cutting systems.



Image source: IMA Schelling Group

LEUCO DIAREX

THE ROBUST HIGH-PERFORMANCE SHANK-TYPE CUTTER FOR EVERYDAY CNC WORK

The LEUCO DIAREX DP shank-type cutter has been one of the most reliable and universal tools in the CNC sector for years. Companies that require robust tools with a durable tooth geometry for daily use in particular are increasingly relying on the DIAREX - and for good reason. Its diamond-tipped cutting edges (DP) and the solid, low-vibration base body ensure exceptionally high stability and a long tool life.

ROBUST CONSTRUCTION - FOR CONSISTENT RESULTS OVER A LONG PERIOD OF TIME

Its optimized tool body reduces vibrations and ensures a smooth milling pattern. The diamond cutting edges offer very long edge life and last even under intensive use. This makes the DIAREX shank-type cutters ideal for all companies that need a reliable "always-on-the-machine tool" for a wide range of materials - from raw particle board and HPL laminated panels to veneered and foil-clad surfaces.

The resharpening area of 1.2 mm enables several reprocessing operations, which further increases cost-effectiveness.

WHY Z2 IS THE BEST CHOICE FOR MANY APPLICATIONS

In theory, tools with a higher number of teeth enable higher feed speeds. However, practical CNC machining shows that: Most users work with feed rates of around 10 m/min - a range in which Z2 tools really come into their own. At a speed of 18,000 RPM, this results in a tooth feed of around 0.28 mm, which represents the ideal compromise between quality, smooth running and process reliability for many applications.

Excessive feed rates can put unnecessary strain on both the machine and the tool and generally lead to poorer surfaces and increased wear. If the feed rates are too low, on the other hand, the blades no longer cut cleanly but increasingly rub. This not only causes quality problems such as burn marks, but also significantly reduces the edge life of the tool.

In practice, the DIAREX proves to be an extremely versatile tool and covers a wide range of typical CNC machining operations.



LEUCO DIAREX - the everyday hero among CNC routers: durable, low-vibration and perfect for reliable results in all common wood-based materials.

For jointing, rabbeting and grooving. Cut-outs can also be produced, either by direct plunge-cutting or via a helical movement. In this way, even small cut-outs from around 20 mm in diameter can be produced safely and efficiently with an 18 mm cutter.

However, it is not only the tool itself that is important for maximum precision, but also the correct holder. The DIAREX develops its full potential when used in high-quality clamping systems - ideally in heat-shrinking chucks or hydraulic expansion chucks. These clamping elements guarantee minimal radial runout, minimize vibrations and ensure that the quality achieved remains constant over a long period of time.

The DIAREX was designed to be a real everyday hero. It withstands high stresses, retains its shape and reliably delivers clean edges. For most companies, this makes it not only a premium milling cutter, but also the best choice for everyday use.

The hydraulic chuck (right) has a radial runout of 0.006 mm, while that of the heat-shrinking chuck is 0.003 mm. This makes them significantly more precise than collet chucks (radial runout 0.02-0.06 mm) - and therefore ideally suited in combination with DIAREX cutters.





MORE POWER THROUGH AIR

TOOLS WITH AIR CHANNELS SET NEW STANDARDS IN CHIP EVACUATION AND EDGE LIFE

YOUR OPTIONS

MAGENTIFY



Air exactly where it works: LEUCO tools carry the air coming through the IDZ Spindle directly to the cutting edges via fine holes in the gullet, thus ensuring cool tools, clear grooving and stable milling processes.

Cramped machining areas present special challenges for CNC production. When nesting is involved, controlled chip evacuation in combination with effective tool cooling becomes crucial for process quality, edge life and the need for cleaning. LEUCO tools with an integrated air channel address precisely this need and offer users a significant gain in performance during the daily work.

By supplying compressed air internally, the new HOMAG IDZ milling spindles guide air through the tool holder and to the tool, while the LEUCO tools with specifically positioned holes guide it directly to the cutting edges. This ensures a precise, permanently available air flow at the cutting zone, which significantly improves cooling, chip evacuation and process stability. Moreover, other machine manufacturers in the woodworking industry and suppliers of retrofit units also offer the option of integrating an internal compressed air supply into existing systems. The IDZ data clearly shows that tools with a compressed air channel run noticeably cooler under identical machining conditions than comparable systems without an air channel, a clearly benefiting tool life and cutting quality.

CONTROLLED CHIP FLOW FOR CLEAN MILLING RESULTS

In addition to cooling, the air flow improves chip evacuation in particular. The air flow keeps the gullet clear, reduces residue buildup in the grooves and effectively prevents multiple hogging and burn marks, the most common causes of worsening cutting patterns and increased tool wear. Studies confirm that inefficient chip evacuation during nested machining operations leads to quality losses and machine stress, especially because narrow contours and blocked milling paths hinder extraction. Active chip guidance ensures significantly more stable processes.

PROVEN SOLUTIONS IN PRACTICE

An example from the caravan industry shows how great the effect can be in practice. One user uses LEUCO tools with air channels in combination with a LEUCO Fibonacci arrangement of cutting edges and achieves impressive results. The edge life in this application increased by 20 to 25 percent, which translates directly into lower tool costs and greater production stability. In addition, contamination of the workpieces and machine components in the process was reduced by around 80 percent. The few residual chips that remain on the panel or in the grooves can be easily removed with a simple cleaning run. This not only makes the milling pattern cleaner, but also makes the entire production process more efficient. The workpieces can be stacked directly afterwards with virtually no manual re-cleaning, which significantly reduces the amount of handling and noticeably speeds up processes.

POWERFUL TOOL SOLUTION WITH MEASURABLE ADDED VALUE

The result is a tool system that is not only technically impressive, but also delivers measurable economic benefits. LEUCO tools with an air channel combine precise cooling air control, controlled chip flow and robust cutting technology to create a solution that gives users a real advantage in everyday CNC work. The function and proven tooth geometry of the cutters used remain unchanged, allowing users to benefit from the advantages of air guidance without having to make any adjustments. All tools with an air channel are currently available on request. Achieve longer edge life, clean cuts, less need for cleaning and stable processes with LEUCO tools with an air channel.



left: With the LEUCO Fibonacci nesting cutter, the air is guided right into the bottom of the groove, thereby efficiently removing chips from the groove and ensuring a clean, low-heat cutting process.

right: During the joining process, the air can be guided right up to the cutting edge. This improves chip extraction and reduces adhesion to the tool, particularly when processing dust-intensive materials such as plasterboard or solid-core panels.

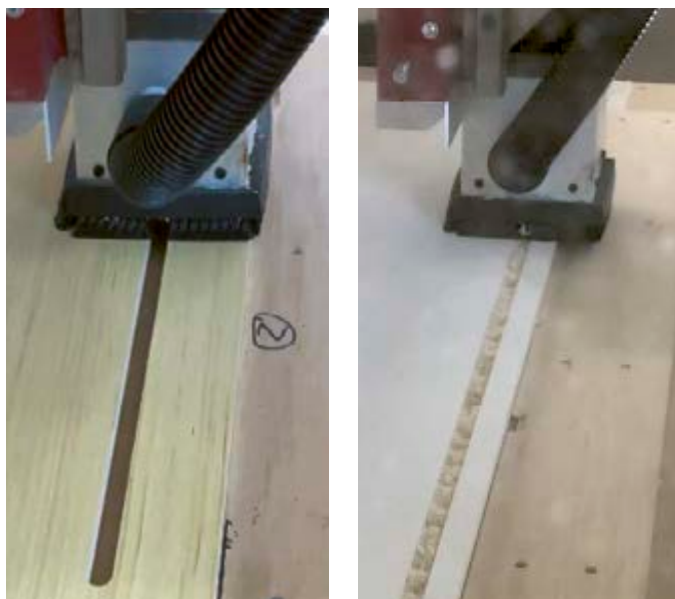

Air flow directed right into the bottom of the gullet: On the left, Fibonacci-Nesting cutter with IDZ for almost chip-free grooving; on the right, milling process without IDZ with increased chip accumulation.

IMPROVED VERSION

FLEXIBLE, PRECISE, CHILD'S PLAY: THE LEUCO SYNCHRONOUS SWIVEL CUTTERHEAD IS BACK

With the comeback of the LEUCO synchronous swivel cutterhead, a tried and tested tool returns to the range - redesigned, more robust and with a large swivel range. The new cutter is perfect for joining and chamfering on 3-axis CNC machines.

With the increasing use of compact 3-axis CNC machines for upright panel processing in particular, the demand for flexible, quickly adjustable swivel cutterheads is rising again. LEUCO has picked up on this trend and offers a tool that optimally combines efficiency, ease of use and precision.

SYNCHRONIZED ADJUSTMENT - READY FOR USE IN NO TIME AT ALL

With an extended range of movement and central, synchronous precision adjustment via a rotary wheel, the enhanced swivel cutterhead has returned to the LEUCO product range. The adjustment is precise and surprisingly simple: Loosen the screws, turn the wheel - done. With one complete rotation, the cutting jaws move parallel by 10 degrees. No readjustment, no room for error.

Conventional swivel tools require a great deal of dexterity and entail the risk of imbalances due to unevenly adjusted jaws - a problem that puts unnecessary strain on the motor bearings. The LEUCO solution prevents precisely this and ensures balancing accuracy and smooth running.

Principle: Loosen the locking screws, turn the adjusting wheel - infinitely variable, precise, both cutting ranges synchronized from 45° to $+70^\circ$. Tighten the locking screws. Milling - precise, low-vibration, reliable.

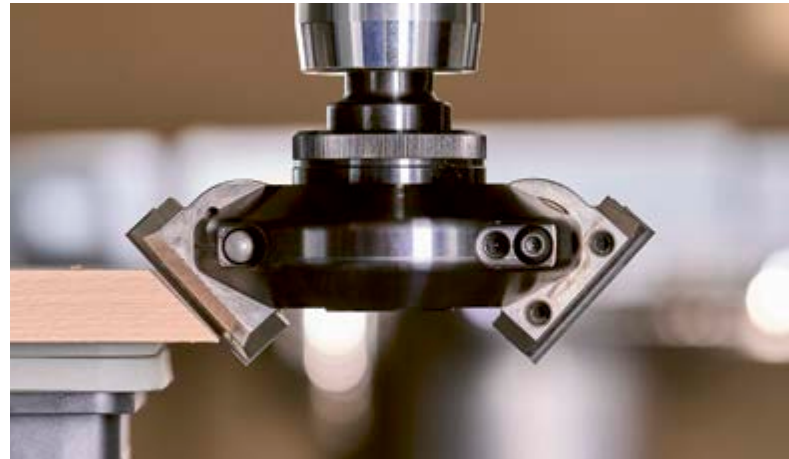

Back in the range with new operating convenience: the LEUCO synchronous swivel cutterhead. The new cutter is perfect for joining and chamfering on 3-axis CNC machines.

This is a big advantage: Despite its compact design, the head offers a cutting edge width of 50 mm - ideal for versatile machining operations.

ANY ANGLE - INFINITELY VARIABLE

The generously dimensioned swivel range of -45° to $+70^\circ$ opens up new possibilities in machining - from precise joining and clean chamfers to demanding mitre cuts. Locking screws fix the selected swivel angle with the security of an anchor.

The robust mechanics are designed for long-lasting continuous operation - a precision tool that can also withstand high loads.

LEUCO TOOL TECHNOLOGY - NOW AVAILABLE IN TOP QUALITY

Whether in small businesses or industrial production lines: The new LEUCO synchronous swivel cutterhead is aimed at anyone who values maximum flexibility, convenient operation and constant precision. The new version is available from stock with a diameter of 125 mm in the neutral position, a 25 mm shaft and a cutting width of 50 mm. On request, the head can also be supplied with turnover knives suitable for rabbeting.

This is how it works:
Video on the LEUCO Youtube channel
👉 www.youtube.com/leucotooling

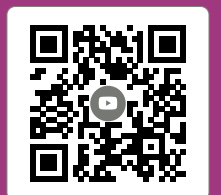

HIGH-PERFORMANCE COATINGS

MAXIMIZING THE PERFORMANCE OF COMPOSITE PROCESSING TOOLS

Polycrystalline diamond (PCD) is an established cutting material in composite machining and impresses with its outstanding hardness and wear resistance. However, PCD tools are limited in their geometry and are not always ideal for highly complex applications. This is where CVD diamond coatings come into play: they combine the advantages of diamond with the design flexibility of carbide tools.

CVD DIAMOND COATINGS

With LEUCO DIACOAT (USA: LEUCO RX), LEUCO offers the latest generation of a CVD (Chemical Vapor Deposition) diamond coating. It is characterized by extreme hardness, high abrasion resistance and optimized adhesion, which considerably extends the service life of carbide-tipped tools. This coating offers an ideal solution for drill bits, reamers, countersinks and milling cutters used to machine composites particular. The variable coating thickness of 3-17 µm enables precise adaptation to the respective application in order to minimize wear and ensure dimensional accuracy.

DLC COATINGS

For applications that require tools made of HSS or metal matrix alloys, LEUCO relies on the TOPCOAT 111 coating (USA: LEUCO BX Coating) - a diamond-like carbon coating (DLC). It impresses with its high hardness, low coefficients of friction and excellent sliding properties, which makes it particularly suitable for machining composite materials in combination with non-ferrous metals.

IN ADDITION TO THE COATING, TOOL GEOMETRY IS ALSO CRUCIAL

It influences the cutting behavior, but also how well a coating adheres to the tool. The tool geometry and coating must be precisely matched. LEUCO therefore develops tools that are specially optimized for use on modern CNC machines. Drill reamers with progressive reaming surfaces reduce delamination effects, while faceted drill bits with special point angles minimize cutting pressure. By combining drilling and countersinking steps, boring countersinks ensure a highly efficient machining process.

LEUCO's expertise in research and development results in tools that are perfectly tailored to industrial requirements. Moreover, LEUCO offers several product families that are already available from stock, with coating, as a standard product.

Tools with a "CVD" coating are easily recognizable by their dark color. When machining composites, the coatings maximize the service life of tools whose geometry can ideally only be produced from wear-prone carbide.

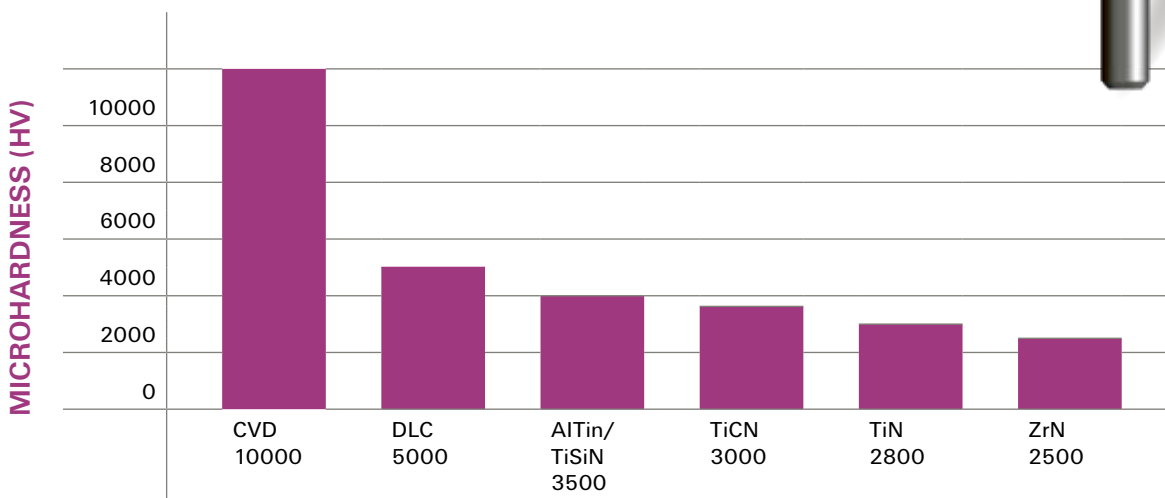

Coatings increase wear resistance by increasing surface hardness and thus the tool life of metal-carbide tools. A TiCN (titanium carbide) coating has a hardness of approx. 3,000 HV, a DLC coating one of 5,000 HV. At 10,000 HV, the CVD coating achieves the greatest effect and is therefore comparable to polycrystalline diamond.



FINGER JOINT CUTTERS FROM LEUCO

THE BENEFIT LIES IN THE DETAILS

Finger joint cutters are most often used in the form of standard tools - although modifications to these tools often enable enormous advances. Detail modifications on finger joint cutters often bring about huge improvements. Frequently, extending the edge lives by several times or eliminating production errors can be achieved. This is the reason why LEUCO offers tools that are always tailored to the customers requirements.

That is why LEUCO offers customized tools that are adapted to the woods processed and the machine. For instance, the moisture content of the wood can differ significantly, depending on the suppliers of a sawmill. Some mills process a wider range of wood species, while in others the material is broadly similar in properties. Torn fibers almost always occur during cutting of finger joints, but to varying degrees. These must be minimized in order to avoid reworking by planing. LEUCO addresses all of these special issues in the customized design of finger joint cutters.

TOOL OPTIMIZATION ALWAYS STARTS WITH A THOROUGH ANALYSIS OF THE PRODUCTION SITUATION.

During this process, the LEUCO team inspects the machines used, the material stock and the fingers produced. What kind of wood material does the mill process? Is there room for improvement in the connections between parties? This, together with the tool edge life, shows the current status of the finger production. LEUCO then implements the improvements requested by the customer. The focus can be on greatly extended runs and better quality. For this purpose, the geometry of the tool is modified, often in combination with a wear-reducing coating.

LEUCO IS ALSO INVOLVED IN FIRST-TIME USE OF THE CUSTOMIZED TOOL.

Employees of the sawmill and the tool manufacturer assemble the cutter set in the machine, then production starts. If the fingers meet the desired quality standard, the development is complete. Longer tool edge life from optimization of the finger joint cutter pays off very quickly for the user. For example, a tool set useful life of six weeks instead of two weeks previously is often realistic. This eliminates two-thirds of the long tool changeover time and likewise two-thirds of the tool repairs. The investment in better tools thus pays for itself.



LEUCO offers customized tools that are adapted to the woods processed and the machine.

YOUR CAPACITY

MAGENTIFY

EXAMPLES OF PRODUCTION IMPROVEMENTS ↴



Edge life

Since use of it began, edge life has almost tripled to as long as 600,000 cycles and quality has improved substantially.



Feed rate

Higher feed rate, reduced energy consumption and significantly better finger jointing quality



Tool changes

Edge life improved from two tool changes per week to just one change in 9 weeks and optimum machining quality achieved

Comparison of the LEUCO micro finger joint cutter with the previous design: On the left is the previous design, on the right the new design with extended resharpening area as the future standard in the range.

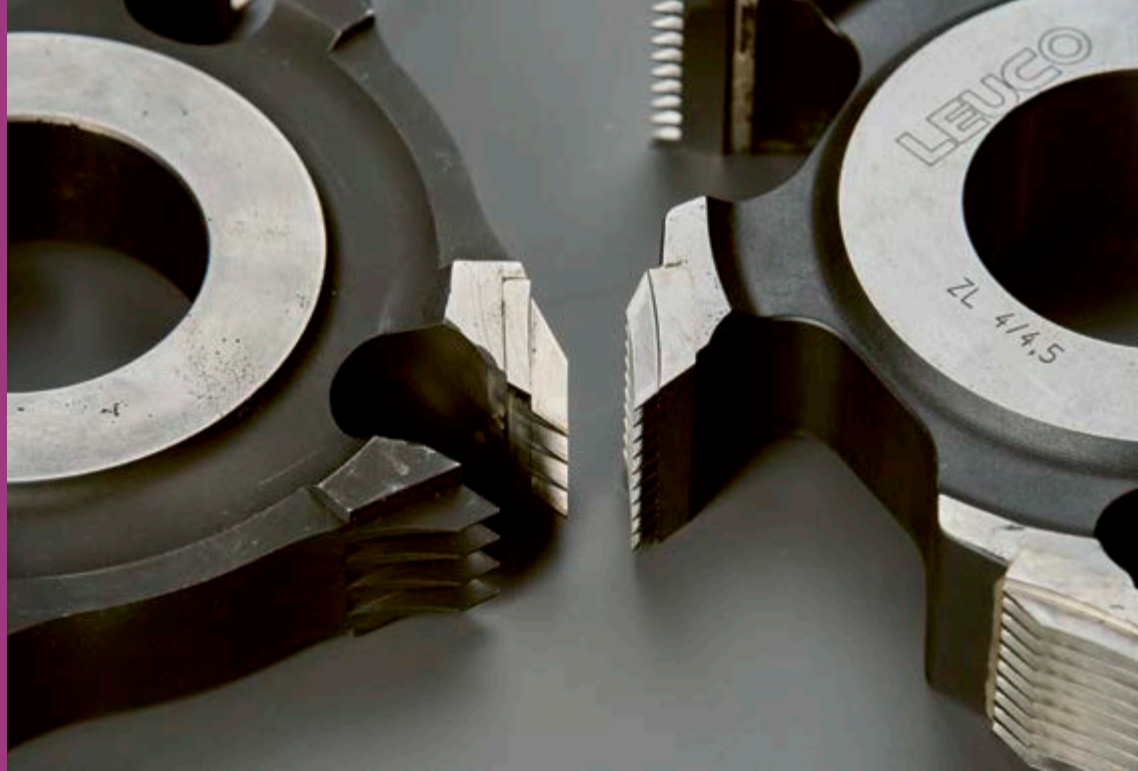

OPTIMIZED MICRO FINGER JOINT CUTTER IMPROVES ECONOMICS OF PRODUCTION

UP TO 10 TIMES MORE RESHARPENING CYCLES

For improved economics of production, LEUCO uses an extended resharpening area for its micro finger joint cutter. The design will become standard in the future. It enables longer edge life, reduces tool changes and lowers costs noticeably.

"If the focus is on working economically, there is hardly any way around this solution," says LEUCO Product Manager Markus Erkenbrecher. The tool is aimed at B2B users in industrial and commercial wood processing.

INCREASED RESHARPENING AREA, LONGER EDGE LIFE

The main improvement lies in the 5 mm larger resharpening area. This means that the micro finger joint cutter can be resharpened up to ten times more often than comparable designs. This significantly extends the service life and considerably reduces tool costs.

This benefit becomes particularly evident during operation of finger-jointing lines and in furniture and window edge production. As a result, the demand for new tools is declining.

APPLICATIONS IN NON-LOAD-BEARING AREAS

Unlike finger joint cutters that produce longer fingers, which are used in load-bearing timber construction - such as glulam beams - the micro finger joint cutter is designed for non-load-bearing applications in furniture and interior construction. Processes in which wood is joined or lengthened are typical.

INNOVATIONS FROM REAL LIFE PRACTICE

The further development was based on experience gained in industrial wood processing, particularly in high-volume applications where edge life and efficiency are crucial.

LEUCO has many years of experience in the field of finger-joint cutting tools and has already established standards for edge life, wear resistance and process reliability with high-alloy cutting materials such as "HS Solid 24" and optional coatings. On this basis, development focussed specifically on optimizing the geometry of the micro finger joint cutter solution and putting it into practical use.

With this further development, LEUCO is expanding its range of finger joint cutters in a consistent manner, thereby increasing productivity and efficiency in industrial wood processing.

LEUCO APP: TOOL DATA AT YOUR FINGERTIPS

NEW FUNCTIONS

Three key functions have been added to LEUCO's Tool Info app: a new search logic for the tool history, flexible lists for individual organization and the option to remove specific entries to keep the database precise and up-to-date. Use of the app is thus evolving from a purely digital data display to a tool that noticeably simplifies day-to-day work. Tool data is available quickly, clearly and application-related.

"Our overriding aim with the app is to offer our customers more benefits: through information that is not just somewhere, but is available wherever it is needed," says Paul Götz, Head of Product Management at LEUCO, describing the idea behind the Tool Info app. This statement also characterizes the new functions, which significantly simplify the handling of tool data in operation.

FIND FASTER, STRUCTURE FLEXIBLY, CLEAN UP IN A TARGETED MANNER

The new search function makes access to the tool history much more efficient. Instead of long lists, just a few entries are enough to quickly find the right tools. "If many tools are stored in the app, you can search specifically for individual tools - for

example for a T3 cutter or diameter 125. The app immediately delivers all relevant hits," explains Götz.

The list function can also be used to group tools individually - for instance, by machine, project or work process. This creates order on demand instead of rigid system logic. "The list function creates an overview in the app and enables flexible, customer-specific structuring of the tools," explains Götz. Use of the app adapts to the way you work, not the other way around.

As a third function, entries in the tool history can be deleted individually. This ensures a lean, up-to-date database and prevents confusing or outdated inventories. "Previously, the tool history was simply a chronological list of tools without the option to sort or clean up," says Götz. With this extension, the depth of information is retained, while the overview is significantly improved.

Live demonstration: The LEUCO Tool Info app makes tool data, technical information and service histories available on your smartphone at any time. A tool can be added to or removed from a list by swiping to the right.





"With the app, our customers have data available where they need it."

Paul Götz, Head of Product Management at LEUCO

LEUCO TOOL INFO APP - DOWNLOAD NOW!

Making tool data consistently available

The app digitally maps the entire LEUCO tool range - regardless of whether it is saw blades, milling cutters, drills or clamping systems. The central element here is the identification of each individual tool. "Tools can be recorded simply by entering the material or serial number or identified directly by scanning the unique data matrix code engraved on the tool," explains Götz.

The application also provides comprehensive tool information: technical specifications, dimensions, CNC application data and operating instructions. "Basically, we pass on all our tool information to the customer like a digital tool card," says Götz. "It's about making this data available where it is needed."

In addition, the app enables continuous mapping of the tool status. Particularly in the case of serialized tools, service operations and resharpening cycles are continuously recorded and displayed transparently. This means that the condition and any outstanding resharpening of each individual tool can be tracked

at all times - from the first use to the last sharpening. LEUCO also offers post-serialization for older tools in order to integrate tools that have not yet been clearly identified into the digital system. Thanks to the direct store connection, new tools can also be reordered directly from the app.

The app made its debut at Ligna 2025. With its consistent expansion, LEUCO combines data intelligence, transparency and production into an integrated system. Tools are clearly identifiable, information can be used immediately and processes are noticeably more efficient - from initial access to reordering.

LEUCO Tool Info Download



Web App toolinfo.leuco.com



Individual structure: Tools can be flexibly organized in lists by machine, project or process in the LEUCO Tool Info app.



New search functions: For instance, by entering "t3" in the search bar, all associated LEUCO t3-System tools are displayed quickly and clearly.



25 YEARS OF PRECISION AND PARTNERSHIP

LEUCO THAILAND CELEBRATES ITS ANNIVERSARY

In 2026, LEUCO Thailand will celebrate its 25th anniversary – a milestone that stands for a quarter of a century of precision, service, and customer focus. Since its foundation in 2001, the subsidiary has developed into a valued partner for the wood-working and furniture industry in Thailand and neighboring countries.

From the outset, LEUCO Thailand has focused on two core areas: professional sharpening services and expert application advice and sales of new tools.

IMPORTANT DEVELOPMENT STEP IN 2025

LEUCO Thailand moved into new premises in the greater Bangkok area. The focus there is on the modern sharpening service center, equipped with state-of-the-art machinery for regrinding diamond and carbide-tipped tools. Whether circular saw blades, shank and jointing knives, drills, or tooth cutters – every tool is brought back into shape with the highest precision.

With this step, LEUCO Thailand strengthened its support for customers in the panel industry, furniture manufacturing, the cement fiber industry, the



The sharpening service center at LEUCO Thailand is equipped with state-of-the-art machine technology. Pictured are Kumpol Charoentripob, General Manager of LEUCO Thailand (third from left), and Udo Leiber, Managing Director of LEUCO Asia (fourth from left).

composite materials industry, and many other areas.

Behind the success of LEUCO Thailand is a team that is deeply committed to the motto: innovative, trend-setting, and reliable. The team's goal for the coming years is clearly defined. Technical expertise, customer focus, and passion for LEUCO tools will continue to form the foundation of success in the future.



The new premises were inaugurated in 2025 with a traditional Thai ceremony.

LEUCO RESHARPENING SERVICE**GLOBAL EXPERTISE FOR MAXIMUM EDGE LIFE**

Replacement of teeth using equally high-quality original materials is standard practice at LEUCO Service worldwide.



Whether Europe, America or Asia, a clear picture is emerging for LEUCO worldwide: A decisive factor in achieving maximum edge life lies in a sharpening strategy planned with longevity in mind. Factors such as workpiece material, machine condition as well as tool geometry influence the service life.

THE RIGHT "WHEN" IS JUST AS IMPORTANT.

Signs of wear such as decreasing cutting quality, burn marks or increasing noise are the same everywhere. In practice, therefore, regular replacement cycles are usually implemented so that tools can be



Dominique Fendeleur (left) has been CEO of LEUCO S.à.r.l. since March 1, 2026. He succeeds Jean-Michel Peter, who is retiring after nine years as CEO and a 36-year career at LEUCO.

LEUCO S.À.R.L

CHANGE ON THE MANAGEMENT BOARD AT LEUCO FRANCE

Jean-Michael Peter, long-standing CEO of LEUCO S.à.r.l., retired at the end of February 2026. He is succeeded by Dr. Dominique Fendeleur.

After more than 36 years with the LEUCO Group, including nine years as CEO, Jean-Michel Peter retired at the end of February 2026. During his time with the company, he promoted the development of LEUCO with commitment, strategic vision, and a sense of responsibility. Under the management board, LEUCO S.à.r.l. consolidated its position, expanded its expertise, and continued its dynamic innovation and growth. His leadership qualities, high professional standards, and commitment to the company's values have had a lasting impact on the team and partners.

To ensure continuity and maintain this momentum, Dr. Dominique Fendeleur took over the position of CEO on March 1, 2026.

Dominique Fendeleur has been with the LEUCO Group since 1997 and has held various strategic positions, most recently as Technical Product Director at LEUCO Production S.à.r.l. His high level of expertise, detailed knowledge of the company, and forward-looking innovative strength make him the ideal person to meet the challenges and achieve the goals facing the Group. This transition is in line with the desire for continuity, stability, and sustainable development of the business.

LEUCO S.a.r.l was founded in 1961 in Ostwald (France, near Strasbourg). Today, LEUCO is one of France's leading suppliers of new tools, grinding services, and consulting in the field of tools for the wood and furniture industry. LEUCO S.a.r.l employs 80 people at its headquarters in Ostwald (department 67) and at its four grinding centers in Meyzieu (69), Ballan Miré (37), Vitrolles (13), and Ostwald (67).

replaced before they reach their wear limit. Moreover, if you wait too long, you risk "overrunning" the tool, which results in disproportionately high wear and economic disadvantages.

EQUALLY IMPORTANT IS THE "WHERE".

LEUCO subsidiaries and partners around the world are highly committed to ensuring that re-sharpening is carried out in accordance with uniform standards. They combine local expertise with the manufacturer's specifications - ensuring consistent quality, reproducible results and high process reliability, regardless of location. Users benefit from consistently high quality, reproducible results and high process reliability, regardless of they are located.

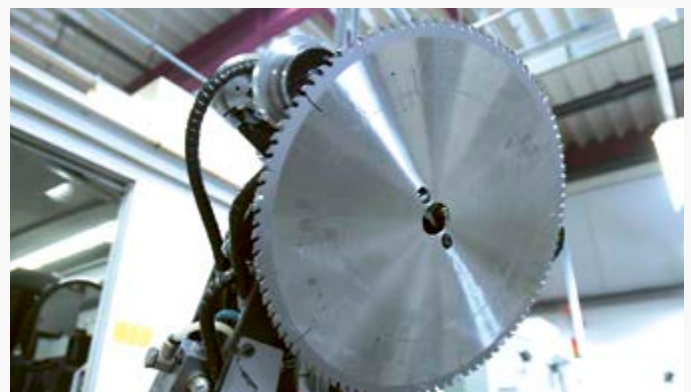

The expertise of the specialist staff and state-of-the-art grinding technology ensure precise material removal from the tooth. "Not too much, but not too little" determines the edge life and number of possible resharpenings.

LEUCO LOCATION BEINHEIM

50 YEARS OF TOOL EXPERTISE FROM ALSACE



For half a century, LEUCO has been manufacturing high-quality circular saw blades and finger joint cutters in Beinheim, France for tradespeople and businesses worldwide. The 7,500 m² production area produces carbide and diamond-tipped tools that set standards in cutting quality, edge life and precision. With state-of-the-art production technology, automation and packaging robots, the site combines tradition, experience and innovative strength.

FROM CRAFT BUSINESS TO HIGH-TECH LOCATION

In 1976, LEUCO relocated the production of saw blades from its headquarters in Horb to Beinheim, around 100 kilometers away and just four kilometers across the German border. The decision for the location in Alsace was based on strategic as well as cultural reasons: sufficient space for expansion, a basic stock of machines from the acquired company as well as experienced employees and values similar to those of the main headquarters in the Black Forest.

From these small beginnings, a modern industrial company with cutting-edge technology has developed on a total production area of 7,500 m². The most recent expansion of 2,200 m² was completed in 2020.

"Beinheim is more than just a production facility. Tools that meet the highest standards worldwide are made here," says Roland Günther, Managing Director of the site, as he looks back on five decades of continuous development.



Roland Günther, Managing Director of the French LEUCO production site Beinheim: "Tools that meet the highest standards worldwide are made here."

History



LEUCO plant, Route du Rhin 20, Beinheim in Alsace: Saw blade production site since 1976. Today a modern production site with 7,500 m² of space, last expanded in 2020.

Continuity in production: A constantly modernized machine park and the know-how of the employees have ensured the high LEUCO quality for decades.



PRODUCTION AT THE HIGHEST LEVEL

Around 130 employees work in production, research and development and administration at the Beinheim site. Tungsten carbide and diamond-tipped saw blades make up the largest share of the range, followed by finger joint cutters and segment hoppers. A total of around 1 million tools are delivered each year and are used in industry, trade and sawmills worldwide. Individual customer requirements are also tailor-made - from thin-cutting parquet saw blades to cross-cut saw blades for non-ferrous materials.

Continued on the next page...

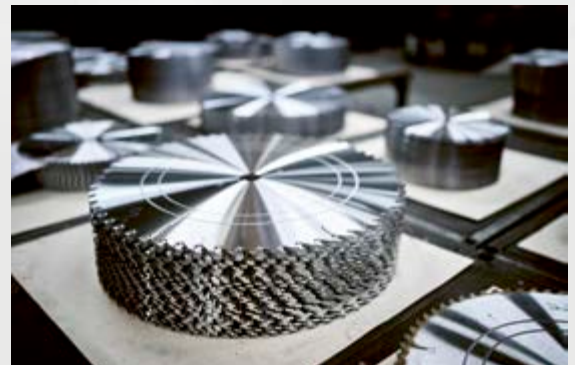

Variety and high-tech at LEUCO: The Beinheim site produces a wide range of **carbide-tipped saw blades** for the wood and furniture industry. Production is highly automated and includes robot-assisted deburring, modern grinding technology and automated brazing of the teeth. Before dispatch, the tools are labeled, picked and prepared for worldwide use in the Autostore in Horb am Neckar.



The site combines state-of-the-art technology and technical expertise in complex tool production: Depending on the design, a saw blade, for example, goes through 15 to 20 work steps. With automation, precise process control and modern packaging robots, the Beinheim plant ensures efficient processes and offers world-class products.

INNOVATION IN EVERY CUT

In addition to the high level of production, the site has also been providing decisive impetus for tool design for five decades. This includes laser cutting for more stable master blades, finer grinding grades and new tooth geometries with excellent cutting quality. A wide range of tungsten carbide and diamond variants and coatings is also

available. Specially developed laser ornaments reduce noise, and specially designed point supports make handling easier.

FIVE DECADES AT THE PULSE OF WOOD PROCESSING

Beinheim stands for expertise and technological leadership. The on-site research and development department is responsible for all new products. Always up to date: Over the last 50 years, the variety of workpiece materials and machines for which circular saw blades and finger joint cutters are used has grown rapidly - and the site has not only accompanied this development, but actively helped to shape it. Always with the aim of producing even more efficient tools.

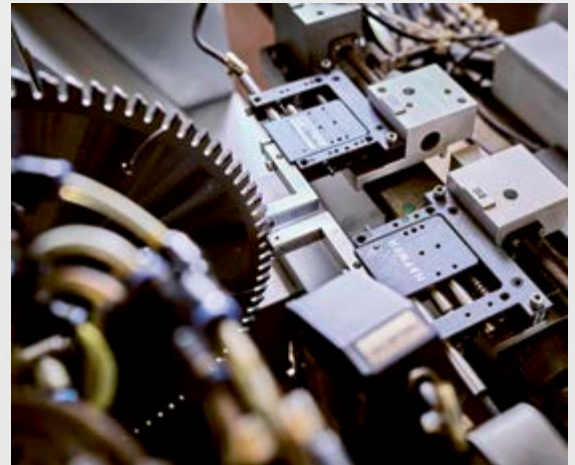

Automated production of diamond-tipped saw blades: The patented LEUCO nn-System saw blade and DIAREX saw blades are produced in the EDM machine park. Quality control is carried out mechanically or optically, depending on the tool type, and is a central component of premium production at LEUCO.

"Our work in Beinheim shows how experience and state-of-the-art expertise go hand in hand. Whether circular saw blades, finger joint cutters or special solutions: Every tool is the result of technical precision and innovative excellence. This makes us a reliable partner for the global wood and furniture industry," says Roland Günther, summarizing the outstanding position of the location.

"Our work in Beinheim shows how experience and state-of-the-art expertise go hand in hand."
Roland Günther, Managing Director of the French LEUCO site in Beinheim

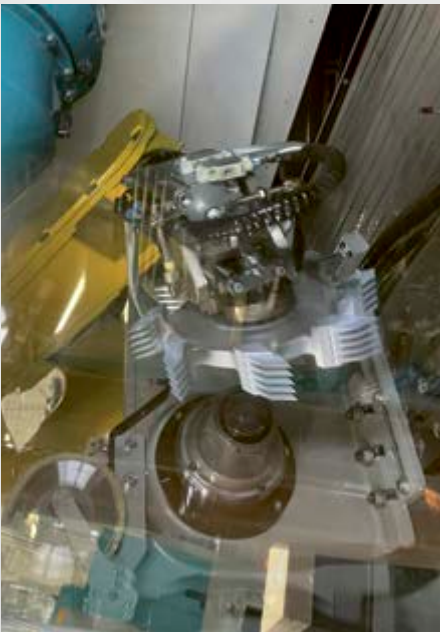

High-end in the production of finger joint cutters: The use of semi-finished products reduces throughput times. A robot continuously feeds the grinding machine with finger joint cutters, while modern grinding technology finishes the cutting edges in the μ range with the highest precision and guarantees exact rotational accuracy.



A LOOK AT LEUCO

LEUCO ranks among the leading international suppliers of complex tools solutions and intelligent services for the wood-working industry.

Our goal is to improve the opportunities for our customers and partners through forward-looking innovations and to open up the potential of wood and related materials as a recyclable raw material to benefit people.

In close contact with our industry, we design and develop tungsten carbide and diamond-tipped circular saw blades, hogs, boring and shank-type tools, drill bits, turnover knives and clamping devices. Our goal is to streamline the processes of our customers in the construction, furniture and panel industry, in lumber mills and interior design companies while also opening up new opportunities in working with the growing variety of materials.

Comprehensive consulting services, our sharpening service at manufacturer quality and future digital tool management solutions have made LEUCO a one-stop tool shop for our customers.

Today, around 1,200 employees work for LEUCO worldwide. With sales subsidiaries in Belarus, Belgium, England, Japan, Poland, Thailand, Ukraine, as well as sales and production locations in China, France, Malaysia, Russia, Switzerland, South Africa and the USA our company has a global presence.

LEUCO
Magentify Wood Processing

1.200 employees worldwide

18 subsidiaries,
93 sales partners
in 64 countries

1954
founded

Leading position in the tool
technology with about
230 patents and protective
briefs

Innovative,
highly modern
logistics center

SAVE THE DATE:

In-house exhibition "LEUCO Treffpunkt"
Sept. 22 - 25, Horb a. N.

Door Industry Days
Nov. 5 - 6, 2026, Horb a. N.

LIGNA 2027,
May 10 - 14, Hanover



LEUCO Online Shop 24/7:
shop.leuco.com



Wood and plastic processing.
Tooling solutions. **Follow us!**
[/leuco-wood-processing](https://www.linkedin.com/company/leuco-wood-processing)